

Angebotszeichnung  
QUOTATION DRAWING

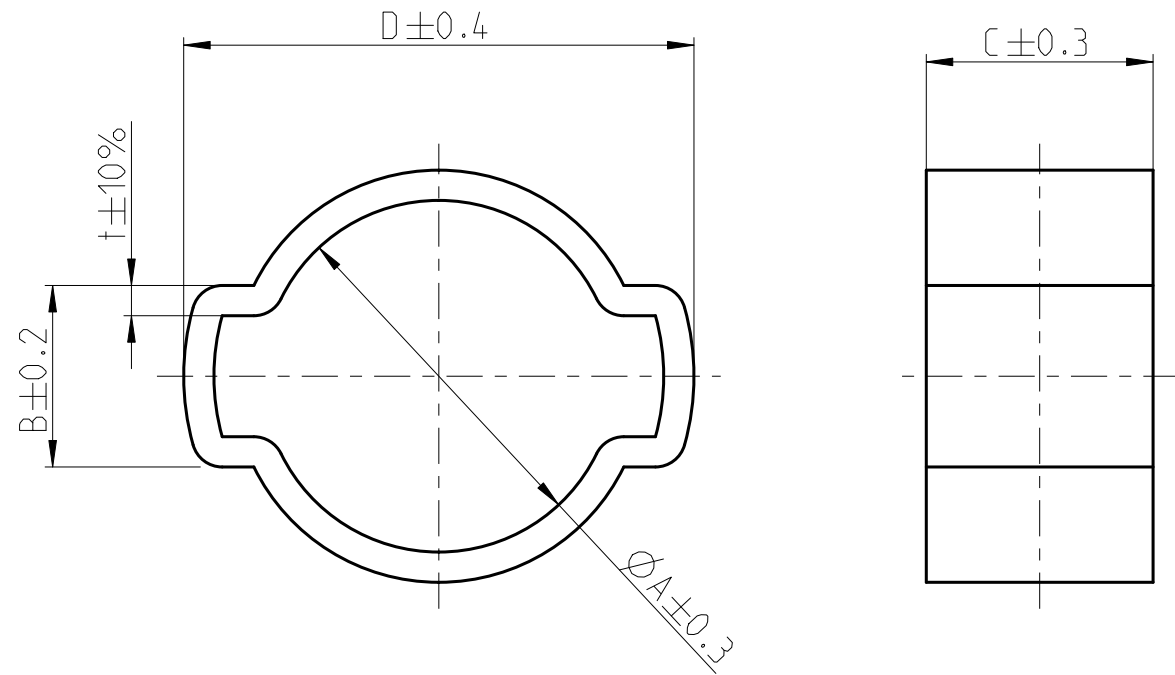

Clip marked with size.

Surface treatment: Fe/Zn 8-10 µm/ TL (Cr3 passivation)

Size	A	B	C	D	t	NORMA no.
5-7	7.3	4.3	6.0	11.0	0.6	0110 0012 007
7-9	9.3	4.8	6.0	13.5	0.8	0110 0012 009
9-11	11.3	5.3	6.5	17.0	0.8	0110 0012 011
10-12	12.3	5.5	6.5	18.0	0.8	0110 0012 012
11-13	13.3	5.8	6.5	19.0	0.9	0110 0012 013
13-15	15.3	6.3	7.0	21.5	1.0	0110 0012 015
14-17	17.5	6.6	7.0	24.0	1.2	0110 0012 017
15-18	18.5	7.0	7.5	25.0	1.2	0110 0012 018
17-20	20.5	7.6	7.5	27.0	1.2	0110 0012 020
18-21	21.5	7.9	8.0	28.0	1.2	0110 0012 021
20-23	23.5	8.5	8.0	31.0	1.3	0110 0012 023
22-25	25.5	9.1	8.5	33.0	1.4	0110 0012 025
23-27	27.5	9.4	8.5	35.0	1.4	0110 0012 027
25-28	28.5	10.0	9.0	36.0	1.4	0110 0012 028
28-31	31.5	10.6	9.0	39.0	1.4	0110 0012 031
31-34	34.5	11.0	9.5	42.0	1.4	0110 0012 034
34-37	37.5	11.5	9.5	46.0	1.6	0110 0012 037
37-40	40.5	12.0	10.0	49.0	1.6	0110 0012 040
40-43	43.5	12.5	10.0	53.0	1.6	0110 0012 043
43-46	46.5	13.0	10.5	56.0	1.6	0110 0012 046

A

-	-	-	-	-	-	-	-	-	-	
-	-	-	-	-	-	-	-	-	-	
-	-	-	-	-	-	-	-	-	-	
-	A	1	Created in Pro/E. Added new diameter 12 mm				01-611317	2013-08-26	Polasek	Krauss
INDEX Teil PART	Zeichg DWG	Anz. QTY.	Aenderung DESCRIPTION				Aend.Nr. CHANGE-NO.	Datum DATE	Bearb. DRAWN	Gepr. CHECKED
Allgemeintoleranz: GENERAL TOLERANCE:		Form- und Lagetoleranz: FORM AND POS. TOL.:		Abmass fuer Winkel: DEVIATION FOR ANGLE:		Gewicht / WEIGHT: errechnet CALCULATED		Volumen: VOLUME:		Pruefkennzeichnung: TEST MARKING:
DIN 6930-f		ISO 2768-K		-		-		- cm <sup>3</sup>		
Projektions-Methode 1 1st ANGLE PROJECTION DIN ISO 128-30		Material: 1.0347		PART NAME: Earclip double d-D W1						
		Material-No.: -								
		Oberflaeche: -								
		SURF. QUAL.: -								
NORMA-Patentnummer: PATENT NUMBER:		Massstab: SCALE:		Datum/DATE		Name/NAME				
		5:1		11.07.07		Krauss				
		-		-		-				
Bandlaenge: LENGTH OF BAND:		Schutzvermerk nach ISO 16016 beachten CONSIDER AFTER PROTECTION NOTICE ISO 16016								
ZNE:										
Ursprung/Anfrage: ENQUIRY-No.:		NORMA Germany GmbH Postfach 1149 • 63461 Maintal		Zeichnungs-Nr./DRAWING-NO.:						
9900010000-013		© COPYRIGHT BY NORMA Group		0110 0012 000						
CAD-SYSTEM Pro/Engineer		DRAWING-NAME: 01100012000_Q		SUB.F.: -				SUB.FROM: -		
				MODEL-NAME: 01100012000				MODEL-TYP: PART		
				DIN A		SHEET: SHEETS				
				3		1   1				
				INDEX PART DWG		TYPE				
				-   A		Q				